

ABOUT PRODUCT

2
Axis

- ❖ ERGONOMIC
- ❖ Opportunity of Over Desktop Application.
- ❖ Opportunity of Attaching Manual Chuck
- ❖ Adjustment of Tilting Angle by means of Manuel HandWheel (0-90°)



OPTIONAL Modifications & Equipments ;

T-SE :Round Worktable T-Side Entry Grooved Thick Table Plate

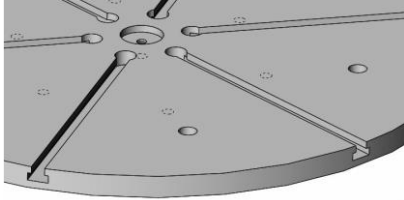

MC : Manual Chuck



Standard Features

- Round Worktable with Slots.
- Adjustable worktable rotation speed by Potentiometer
- Manual Mechanical gear movement for tilting by Handwheel. With opportunity of adjusting at every angle within range.
- 3 m. Power Cable
- Standard Machine Colors:
 - Chassis RAL 7011(Grey)
 - Sheet Covers:RAL 3020(Red)
- Power Supply : 220V - (2 phase)
- Motor : DC Current
- One (1) Year Warranty (wearing parts out of warranty)



❖ All technical specifications are subject to change without prior notice.

Mini BCP

Section-A :WELDING POSITIONER MODELS | A01: Mini-Stationary Types
STANDARD Mini-Conventional Welding Positioner(2AX)



FEATURES



B



C

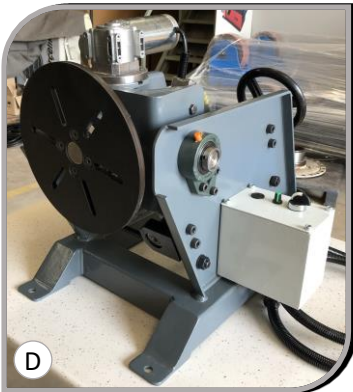

D

Handwheel Manuel Tilt Adjustment

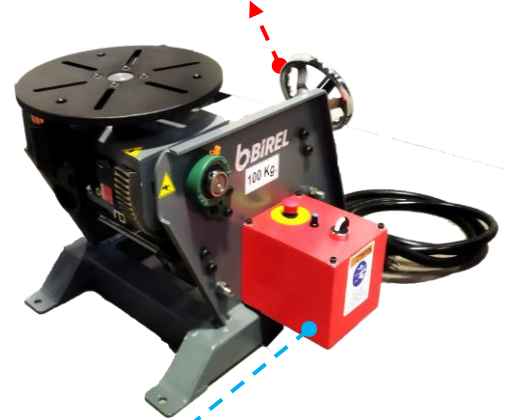

10-Emergency Stop

30-Table Rotation Direction
CW / CCW

20-Table Rotation
Speed Potentiometer

SPECIAL APPLICATIONS upon CUSTOMER REQUEST



❖ All technical specifications are subject to change without prior notice.

Birel Mühendislik Makine San. Tic. A.Ş. | Adresses: Yaylacik Mahallesi Dogancilar Mevkii 46. Sok. No:4/1 Nilüfer/Bursa – TURKEY
Tel: +90 (224) 413 0617 Fax: +90 (224) 413 0618 Web : www.birelmuhendislik.com Contact Email : info@birelmuhendislik.com
Sales: Email: sales@birelmakina.com Direct Mobil: +90.5462016491

TECHNICAL PROPERTIES

Mini-BCP-005 /Mini-BCP 010

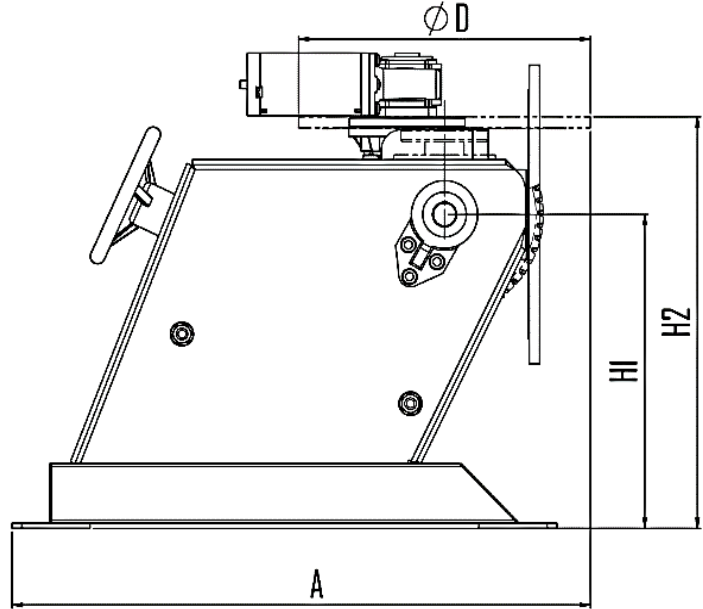
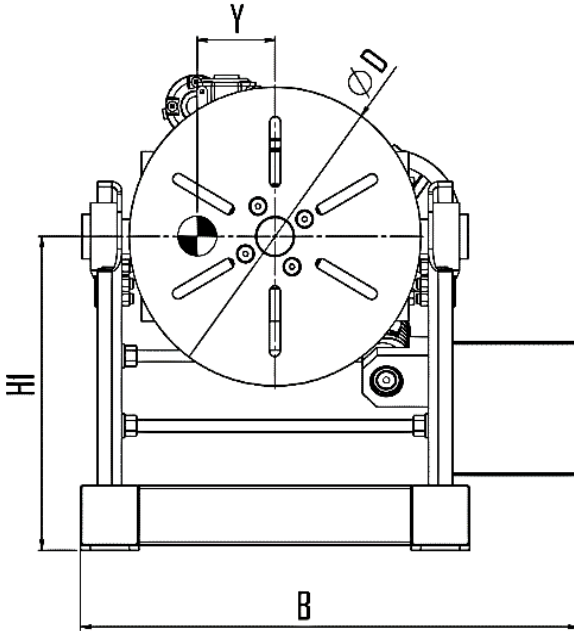

Mini-BCP model	Symb.	Unit	Mini-BCP005	Mini-BCP010
Capacity		kg	50	100
Rotation Speed		rpm	0 - 2,3	0 - 2,3
Max.Rotational Torque		Nm	49	86
Tilting Angle		deg	0 - 90°	0 - 90°
Tilting Torque		Nm	Manual	Manual
Offset Distance	X - Y	mm	Y=50	Y=50
Table Diameter	ØD	mm	250	300
Height (Table Vertical)	H1	mm	315	315
Height (Table Parallel)	H2	mm	411	415
Length	A	mm	570	595
Width	B	mm	463	513
Motor Power of Table		kW	0,1 (DC)	0,1 (DC)
Tilting			Manuel	Manuel
Weight		kg	47	57

↳ Out of these standard capacities, Birel Machinery, according to customer requirements, has the manufacturing possibility at different capacities, sizes.

❖ All technical specifications are subject to change without prior notice.