

## ABOUT PRODUCT



Height  
Adjustable  
By Handwheel



A

## OPTIONAL Modifications &amp; Equipments;

## M01: Manual Upper Pressing

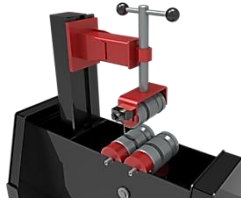

## M02: Welding Torch Holder

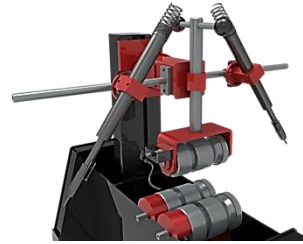

## General Features ;

- BPP model Pipe positioner is used for the purpose of rotation and tilting of pipes with round profiles in manual or automatic welding, mainly in the field of pipe construction, prefabrication and assembly on site.
- Due to rotation of pipe, No interruption is observed in circumferential welding of pipe.
- BPP model Pipe Positioner, as standard, Up and down movement for diameter adjustment is performed mechanically by Manual Wheel. Upon request, Optionally, A quick mounting-detaching equipments can be provided.
- BPP model Pipe Positioner has the capability of tilting in both directions +90°-0°-90° degree (i.e : Opportunity of precisely controlled rotation speeds both in clockwise(CW) or Counterclockwise(CCW) directions.
- BPP model Pipe positioner includes One(1) driven unit as worktable and One(1) unit as idler, upper press.

## Technical Advantages ;

- Birel Machinery as standard provides BPP models in capacities of 300 - 500 - 750 - 1500 - 3000 kg..
- In special conditions, Out of these standard capacities, Birel Machinery, according to customer standards & requirements, has the opportunity of manufacturing possibility at different capacities.
- Motor with brake and forced fan cooling.
- For any special request or project, Please do not hesitate to contact with us.

❖ All technical specifications are subject to change without prior notice.

## APPLICATION ILLUSTRATIONS

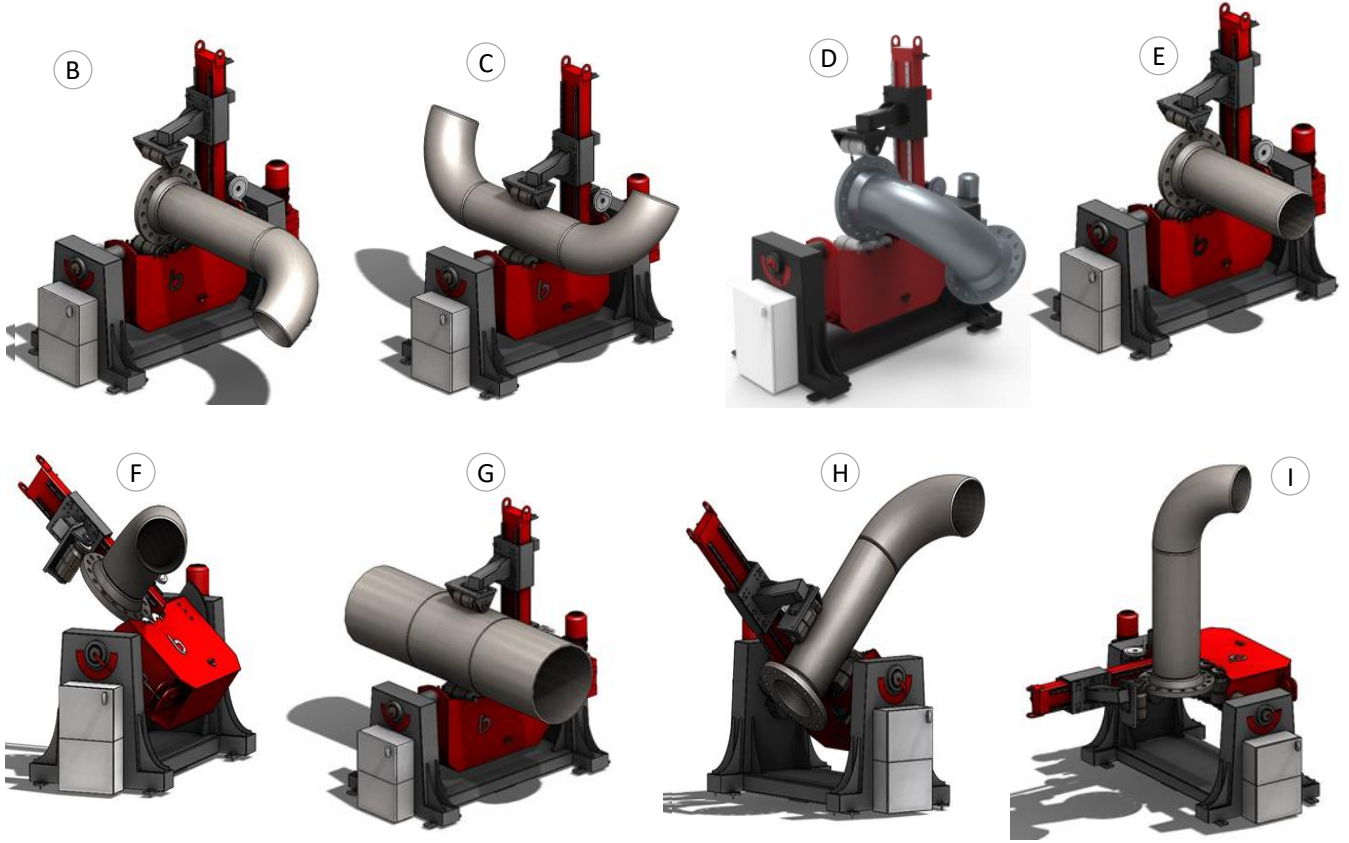

## Standard Features

- Capability of +90-0-90 degree Worktable rotation.
- Up & Down movements for Diameter adjustment are provided by means of manually operated mechanical wheel as standard.
- Adjustable worktable rotation speed
- Rotational Speed Dijital display on Electrical Cabinet
- 5 mt. Command Cable
- 5 mt. Power Cable
- Brake & Fan Cooled Motor (Asynchronous)
- Standard Machine Colors:
  - Chassis RAL 7011(Grey)
  - Sheet Covers:RAL 3020(Red)
- Power Supply: 380V - (3 phase+Neutral +Earthing)
- One (1) Year Warranty (wearing parts out of warranty)

❖ All technical specifications are subject to change without prior notice.

## Optional Control Units

## DFPSE

Double Foot Pedal+Stick+  
Emergency Stop (3 m )



## OHC

Overhead Hangable Control



## WRC

Wireless Remote Control



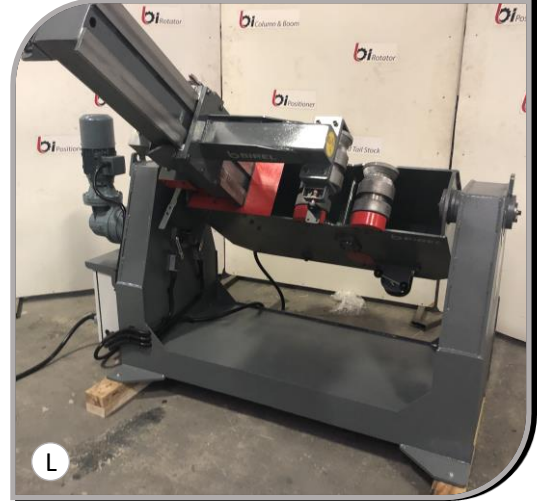

❖ All technical specifications are subject to change without prior notice.

Birel Mühendislik Makine San. Tic. A.Ş. | Adresses: Yaglacik Mahallesi Dogancilar Mevkii 46.Sok. No:4/1 Nilüfer/Bursa – TURKEY  
Tel: +90 (224) 413 06 17 Fax: +90 (224) 413 06 18 Web : [www.birelmuhendislik.com](http://www.birelmuhendislik.com) Contact Email : [info@birelmuhendislik.com](mailto:info@birelmuhendislik.com)  
Sales: Email: [sales@birelmakina.com](mailto:sales@birelmakina.com) Direct Mobil: +90.5462016491

## TECHNICAL PROPERTIES

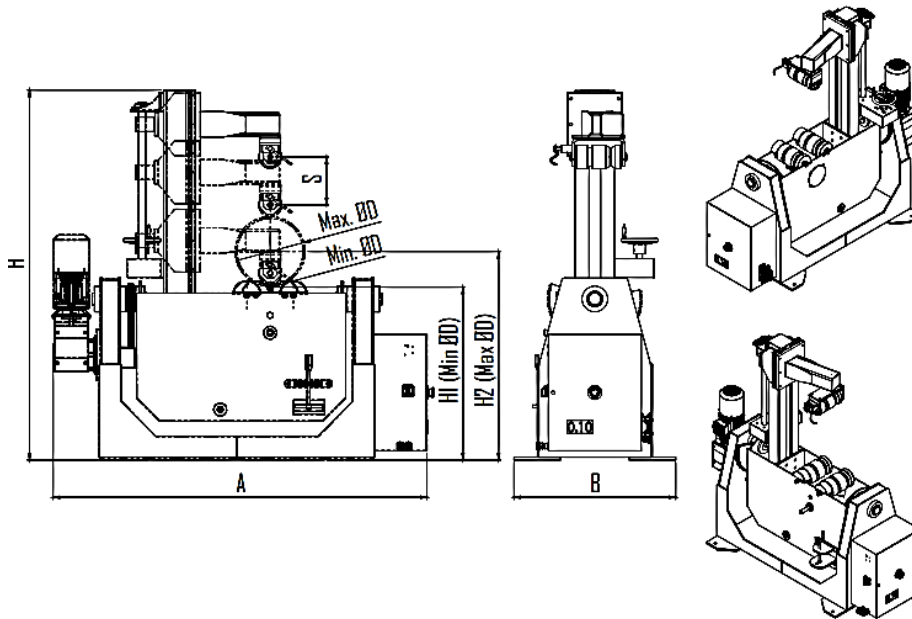
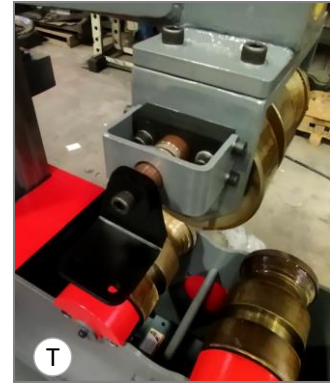

### Technical Details :

Model No : BPP	Symb	Unit	BPP-300	BPP-500	BPP-750	BPP-1000	BPP-1500
Capacity		kg	300	500	750	1 000	1 500
Rotation Speed		mm/min	200 - 1350	200 - 1350	200-1360	200 - 1360	200-1380
Rotation Torque		Nm	260	300	520	740	1050
Tilting Torque		Nm	1680	2130	3340	4150	6540
Pipe Diameter	Ø	mm	20 - 325	20 - 410	35- 460	60 - 510	60 - 610
Roller Material			Steel	Steel	Steel	Steel	Steel
Length	A	mm	1440	1500	1800	2020	2140
Width	B	mm	700	740	840	940	1150
Height	H	mm	1645	1730	1880	2050	2245
Height of Pipe Center - Min.ØD	H1	mm	800	800	890	1000	1095
Height of Pipe Center - Max.ØD	H2	mm	945	990	1090	1215	1360
Loading Strok	S	mm	200	200	200	200	200
Total Motor Power		kW	0,62	0,8	0,8	1	1,12

Out of these std. capacities, Birel Machinery, according to customer requirements, has the manufacturing possibility at different capacities, sizes.

❖ All technical specifications are subject to change without prior notice.