

BLPL
3AX

Chapter-A :WELDING POSITIONER MODELS | A03: Standard Stationary Types
STANDARD L-Type Welding Positioner Model- LIGHT DUTY Version(3AX)

BIREL
MÜHENDİSLİK MAKİNA A.Ş.

ABOUT PRODUCT STANDARD: with Slotted Table & HandBox Cable Remote Control



OPTIONAL Modifications & Equipments;

T-SE :Round Worktable T-Side Entry Grooved Thick Table Plate

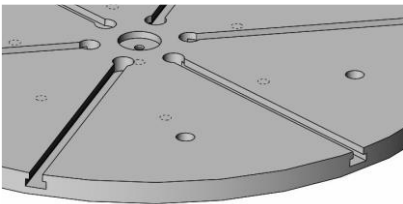

OC-T:Octagonal Table



MC:Manual Chuck



BGR:3 Jaw Manual Pipe Gripper



General Features ;

- BLPL-3AX model 3 axis Head Tail Stock Positioner, Regardless of any geometric shape within dimensions of the machine, In favour of being able to position and generating remarkable welding edges to all workpieces are qualified & ideal solutions. Ensures utmost capability of welding & likewise assembling at 360° degree of any required position .
- Designed in best suitable configuration to perform safe positioning of the workpieces having asymmetry & higher probability of overturn.
- Avoids of crane operations that are part handling, rotating of parts, etc. during production, Provides the opportunity of using operator's working power to use more effectively by minimizing time loss and it increases the efficiency of work.
- BLPL-3AX model positioner with robust construction & easy controlling ability, Provides the opportunity of comfortable working to operator & improves the quality of welding.
- The operators with BLPL-3AX "L" type positioner, At center axis of worktable Workpiece can be precisely rotated over the command control at Clockwise (CW) or Counterclockwise(CCW) at specified speeds.

Technical Advantages ;

- Birel Machinery as standard provides BLPL-3AX models in capacities of 0,75 - 1,5 - 3 ton.
- In special conditions, Out of these standard capacities, Birel Machinery, according to customer standards & requirements, has the opportunity of manufacturing possibility at different capacities.
- Motor with brake and forced fan cooling.
- Welding Arc Group
- Allow quick connection of workpieces by using " T " slots on worktable (Optional)
- For any special request or project, Please do not hesitate to contact with us.

❖ All technical specifications are subject to change without prior notice.

Birel Mühendislik Makine San. Tic. A.Ş. | Adresses: Yaylacik Mahallesi Dogancilar Mevkii 46. Sok. No:4/1 Nilüfer/Bursa – TURKEY
Tel: +90 (224) 413 0617 Fax: +90 (224) 413 0618 Web : www.birelmuhendislik.com Contact Email : info@birelmuhendislik.com
Sales: Email: sales@birelmakina.com Direct Mobil: +90.5462016491

ILLUSTRATIONS

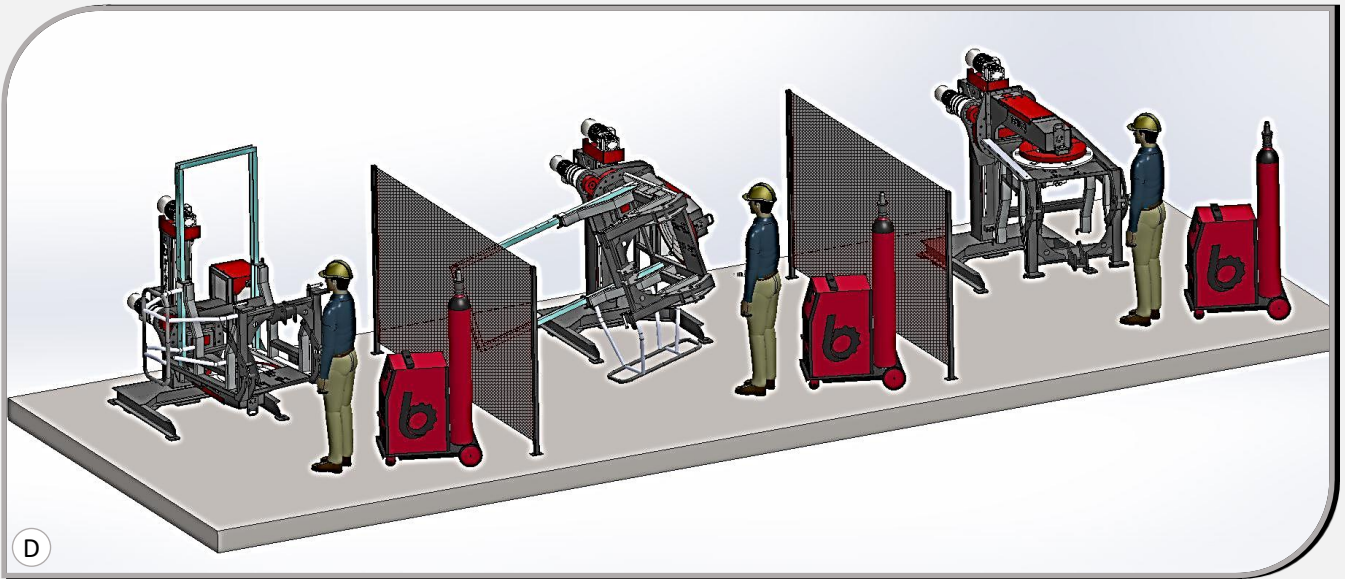

❖ All technical specifications are subject to change without prior notice.

BLPL
3AX

ILLUSTRATIONS

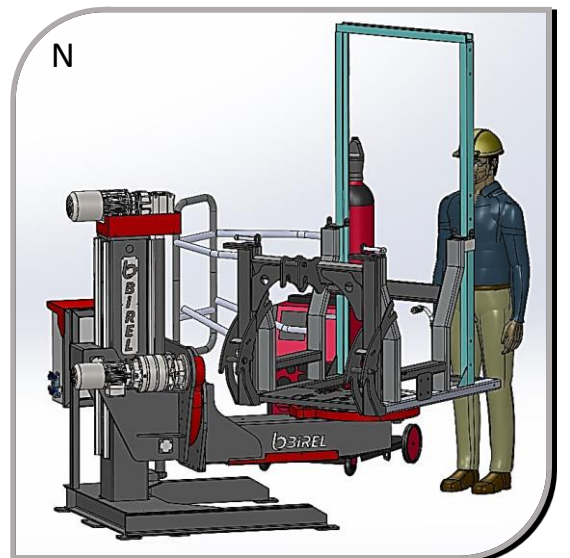
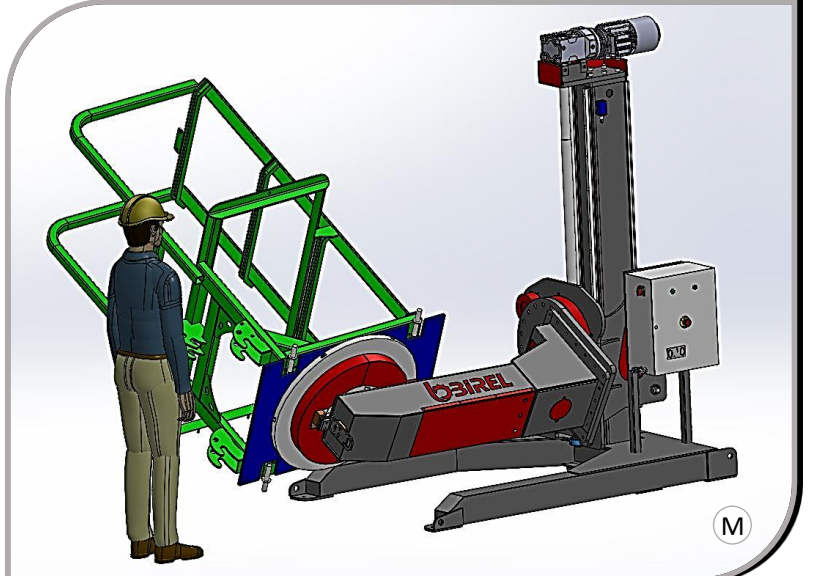
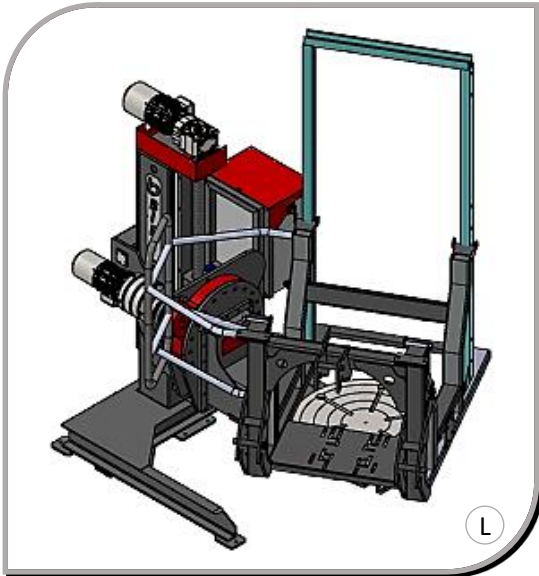

❖ All technical specifications are subject to change without prior notice.

ILLUSTRATIONS

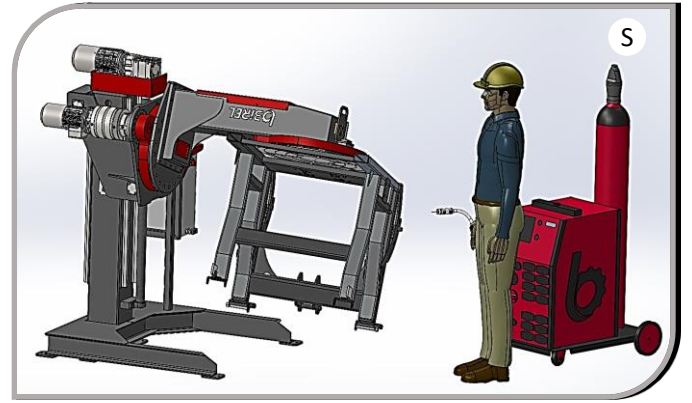
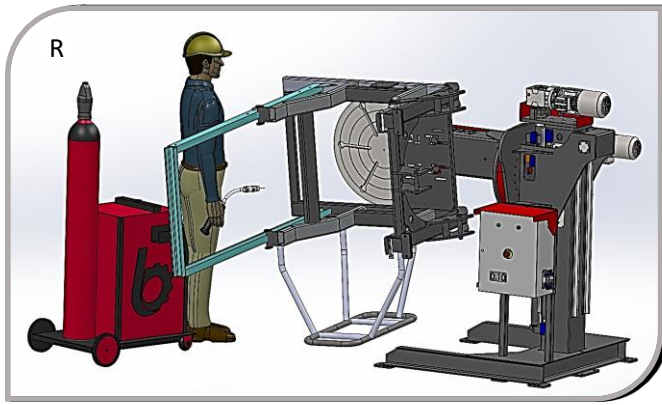

Standard Features

- Capability of 360 degree worktable rotation.
- Round Worktable with Slots.
- Lifting of workpiece vertically by means of Threaded Shaft is presented as standard.
- Adjustable worktable rotation speed & Dijital display on Electrical Cabinet
- 5 mt. Command Cable
- 5 mt. Power Cable
- Brake & Fan Cooled Motor (Asynchronous)
- Welding Arc Group
- Standard Machine Colors:
 - Chassis RAL 7011(Grey)
 - Sheet Covers:RAL 3020(Red)
- Power Supply: 380V - (3 phase+Neutral +Earthing)
- One (1) Year Warranty (Wearing Parts outside of Warranty)

Optional Control Units

DFPSE

Double Foot Pedal+Stick+
Emergency Stop (3 m)



OHC

Overhead Hangable Control



WRC

Wireless Remote Control



❖ All technical specifications are subject to change without prior notice.

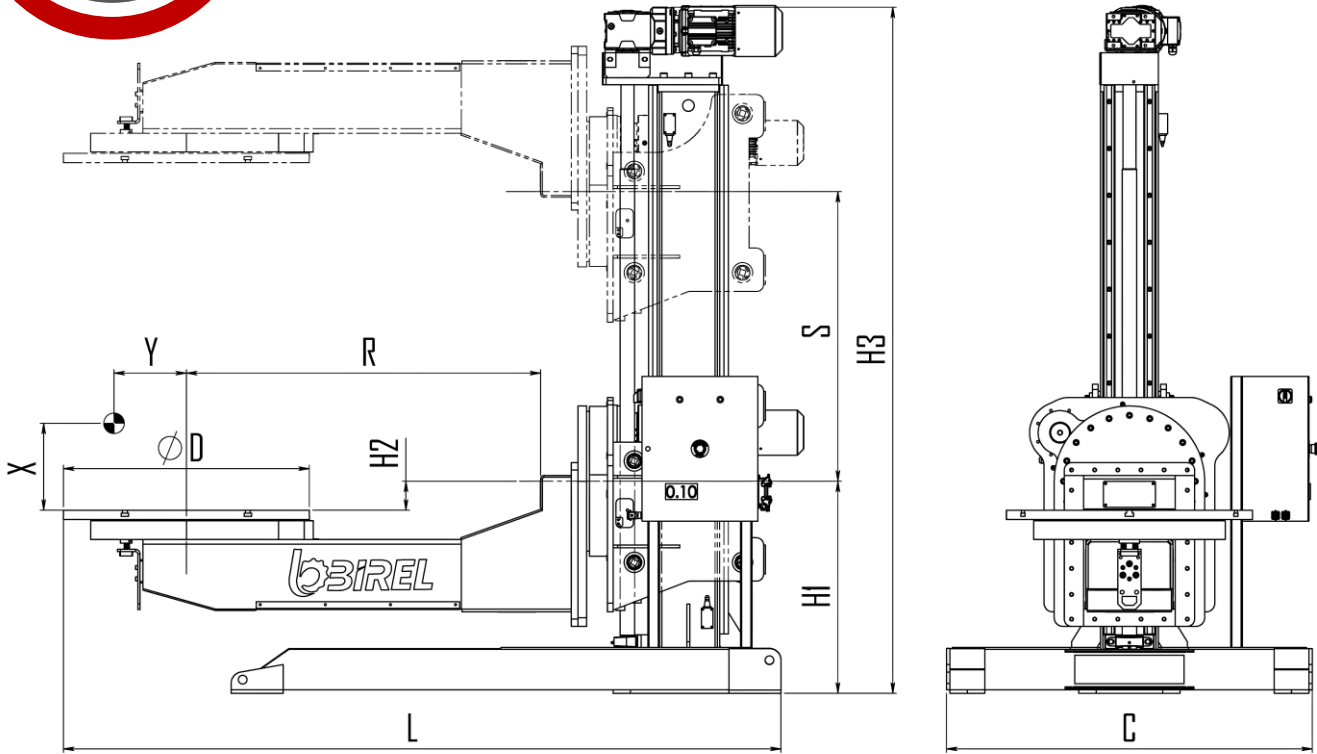

Technical Details :

Model : BLPL-3AX	Symb.	Unit	BLPL050-3AX	BLPL075-3AX	BLPL1,5-3AX	BLPL3-3AX
Capacity		kg	500	750	1 500	3 000
Lifting Stroke	S	mm	550	650	1000	1150
Working Radius	R	mm	1000	1000	1200	1600
Offset Distance	X-Y	mm	450-150	300 - 150	300 - 150	300 - 150
Table Diameter	ØD	mm	700	700	850	1000
Table Torque		Nm	750	1130	2260	4550
Table Speed		rpm	0,15-1,5	0,2 - 1,5	0,2 - 1,4	0,2 - 1
Tilt Torque		Nm	2100	2750	3340	6900
Tilt Speed		rpm	1	0.70	0.70	0.55
Lifting Speed		m/min	0,60	0.60	0.50	0.50
Max. Welding Current		Amp	700	700	700	700
Rotating Center Height	H1	mm	770	680	730	720
Plate Rotating Center Difference	H2	mm	50	144	100	100
Total Height	H3	mm	1900	1910	2380	2630
Total Length	L	mm	2170	2200	2480	3160
Total Width	C	mm	1170	1300	1265	1500
Motor Power of Table		kW	0,37	0,37	0.55	0.75
Motor Power of Tilting		kW	0,37	0,37	0.55	0.75
Motor Power of Lifting		kW	0,75	1.1	1.5	3
Weight		kg	730	1050	1390	2230

↳ Out of these std. capacities, Birel Machinery, according to customer requirements, has the manufacturing possibility at different capacities, sizes.

❖ All technical specifications are subject to change without prior notice.