

ABOUT PRODUCT

Standard Features

- One «1» idler unit.
- Manual Locking System
- Mechanical Diameter Scale Indicator
- Hydraulic Height Adjustment by Handle.
- Polyurethane Coated Rollers
- Standard Machine Colors:
 - Chassis RAL 7011(Grey)
 - Sheet Covers:RAL 3020(Red)
- One (1) Year Warranty (wearing parts out of warranty)



General Features ;

- BHML is designed as a suitable solution to qualified and proper circumferential welding of cylindrical parts according to diameter settings at suitable certain capacities..
- BHML Adjustable diameter Hydraulic Manual Lift minimizes the usage of Crane.
- By easier usage provides saving of time.
- In Pipe welding production , it has an irreplaceable design in centering between Head and Tailstock distances it has an irreplaceable designty
- Although BHML is constituted of single idler unit, If easy movement over a rail arrangement by means of a manual buggy system is requested, By increasing the number of BHML, we can easily provide positioning to more longer parts .
- BHML is produced as standard 3000kg. According to special diameter & load range, we present special customer design production.
- One (1) Year Warranty (wearing parts out of warranty)

Application illustrations ;

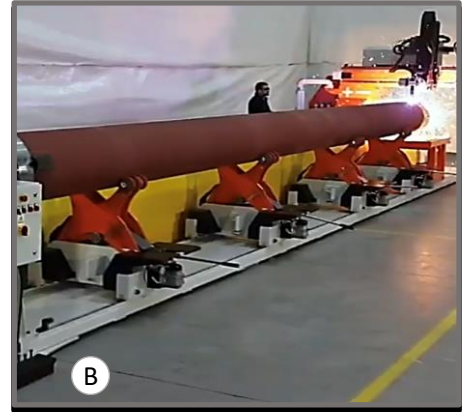

❖ All technical specifications are subject to change without prior notice.

TECNICAL PROPERTIES

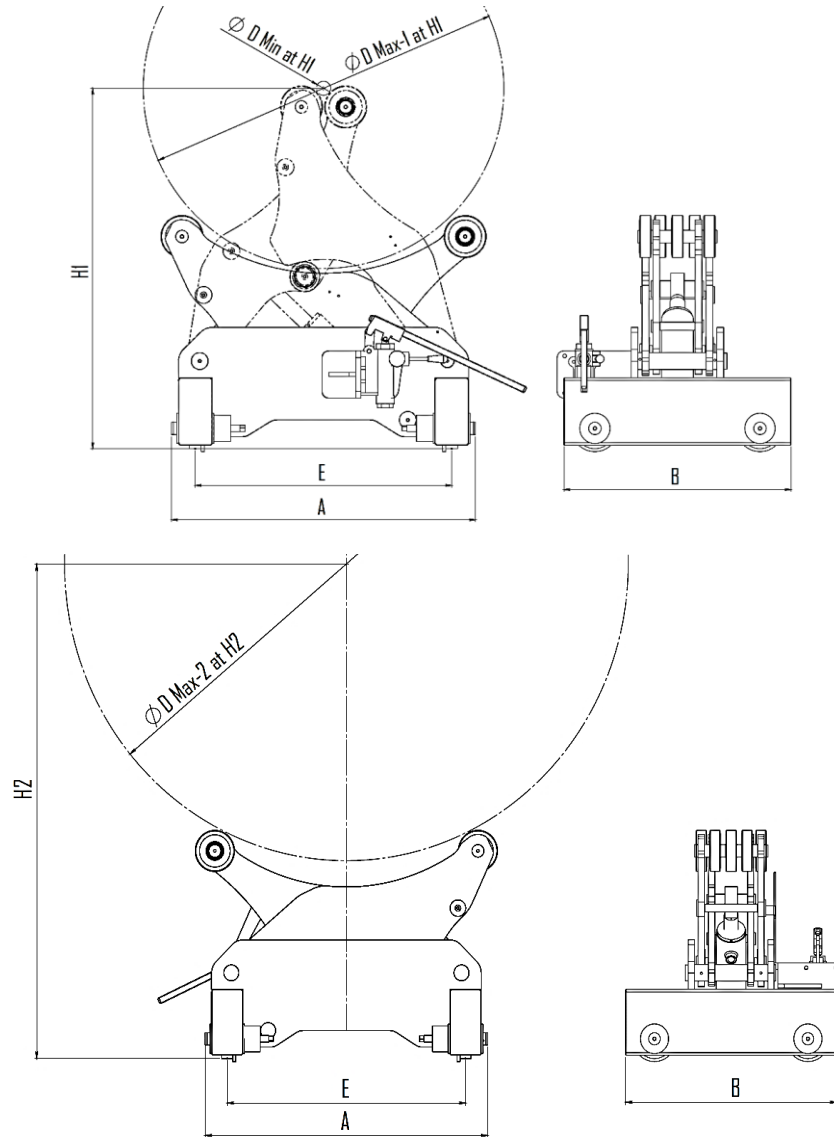

Technical Details :

Model : BHML	Symb.	Unit	BHML-3
Capacity		kg	3 000
Min.-Max.Rolling Ø – H1 Height	ØDmin at H1-ØDmax-1 at H1	mm	50 – 1070
Max.Rolling Ø – H2 Height	ØD Max- at H2	mm	1800
Height	H1-H2	mm	1070-1500
Rail Axis	E	mm	770
Width	A	mm	900
Length	B	mm	670
Weight		kg	320

↳ Out of these std. capacities, Birel Machinery, according to customer requirements has the manufacturing possibility at different capacities, sizes.

❖ All technical specifications are subject to change without prior notice.