

ABOUT PRODUCT

STANDARD: HandBox Cable Remote Control

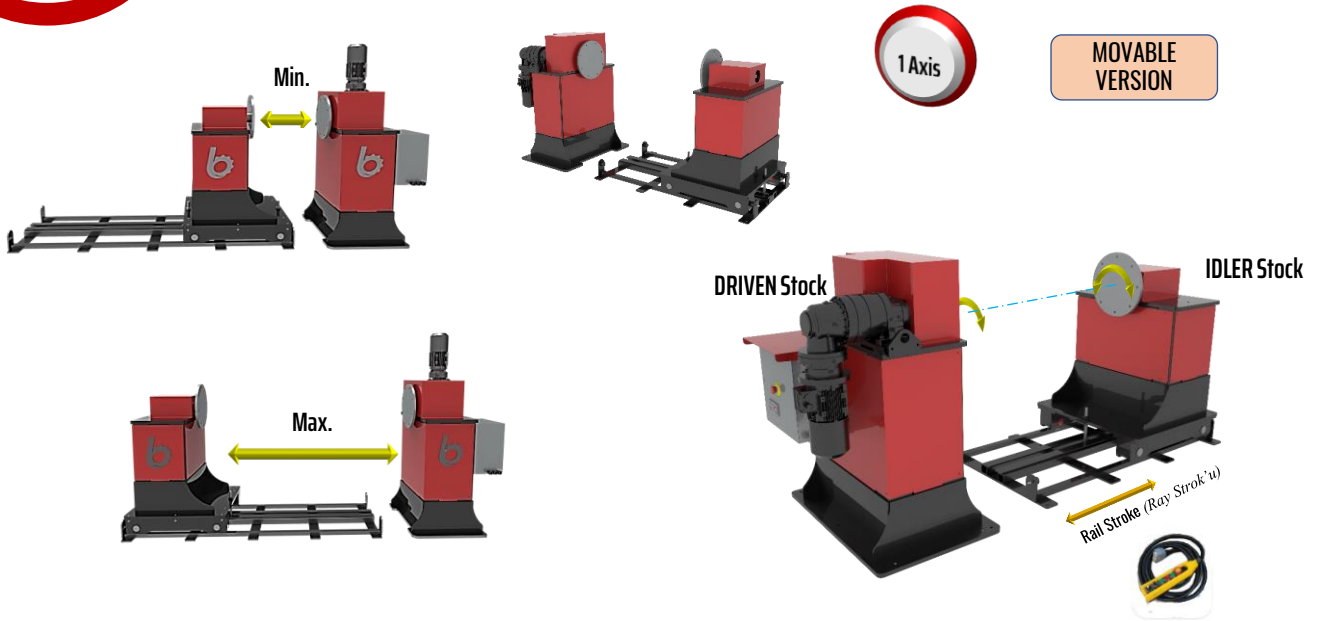

OPTIONAL Modifications & Equipments;

EFFA : Easy Fixture Fixing Apparatus



T-SE :Round Worktable T-Side Entry Grooved Thick Table Plate

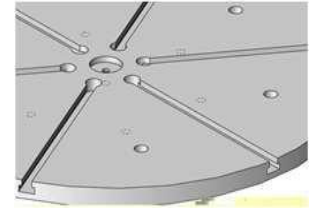

General Features ;

- BEMG-1AX model 1 axis Head Tail Stock Positioner, Regardless of any geometric shape within dimensions of the machine, In favour of being able to position and generating remarkable welding edges to all workpieces are qualified & ideal solutions. Ensures utmost capability of welding & likewise assembling at 360° degree of any required position .
- By means of the equipment presented as optional that provides quick mounting-detaching opportunity and having 360° rotation capability provides ergonomical operation environment
- BEMG-1AX chassis positioner is constituted of mutually One(1) driven body & One(1) idler body.
- The operators with BEMG-1AX type positioner, At center axis of worktable Workpiece can be precisely rotated over the command control at Clockwise (CW) or Counterclockwise(CCW) at specified speeds.

❖ All technical specifications are subject to change without prior notice.

Technical Advantages ;

- Birel Machinery as standard provides BEMG-1AX models in capacities of
- 1 - 2 - 3 - 5 ton.
- In special conditions, Out of these standard capacities, Birel Machinery, according to customer standards & requirements, has the opportunity of manufacturing possibility at different capacities.
- Motor with brake and forced fan cooling.
- Welding Arc Group (Optional)
- Allow quick connection of workpieces by using " T " slots on worktable (Optional)
- For any special request or project, Please do not hesitate to contact with us.

ILLUSTRATIONS

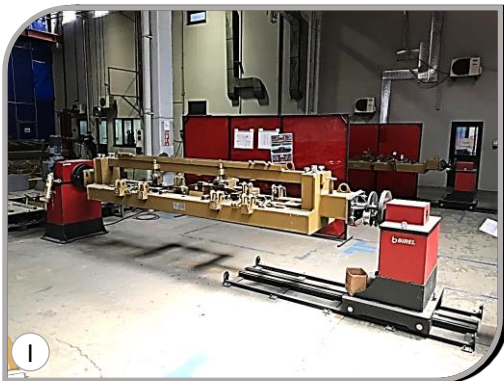
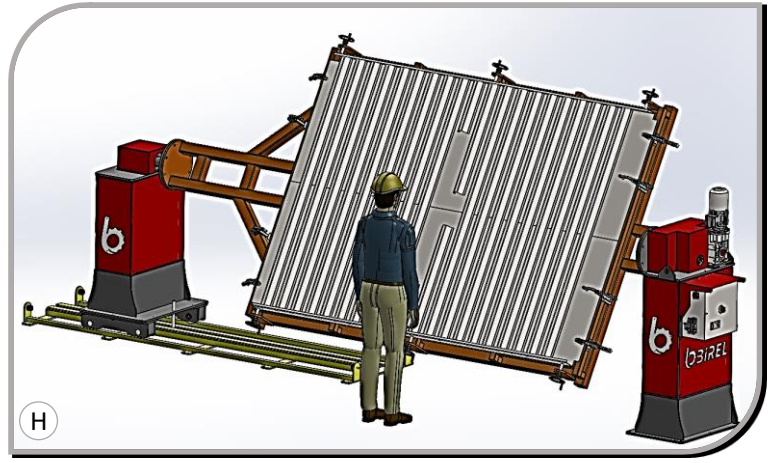
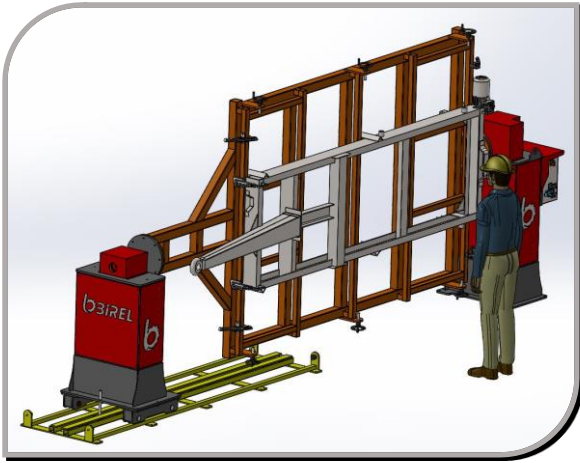
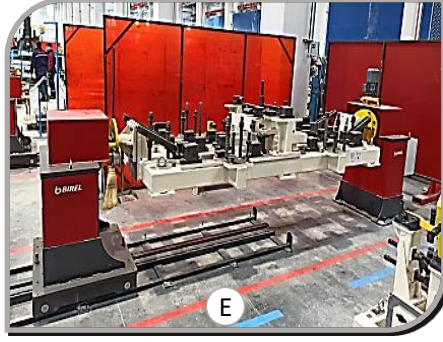
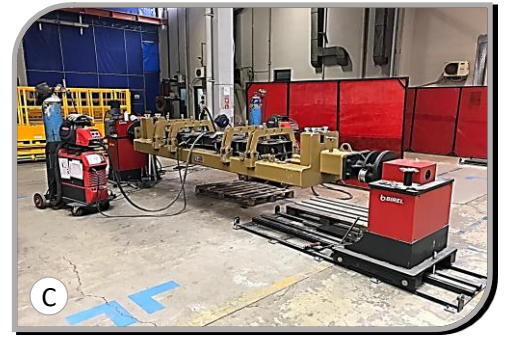

❖ All technical specifications are subject to change without prior notice.

ILLUSTRATIONS

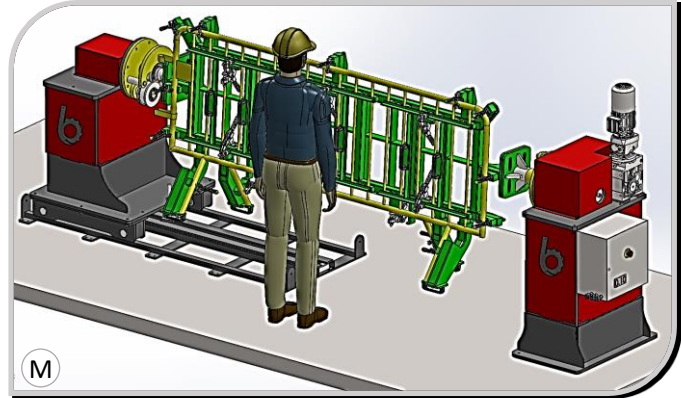
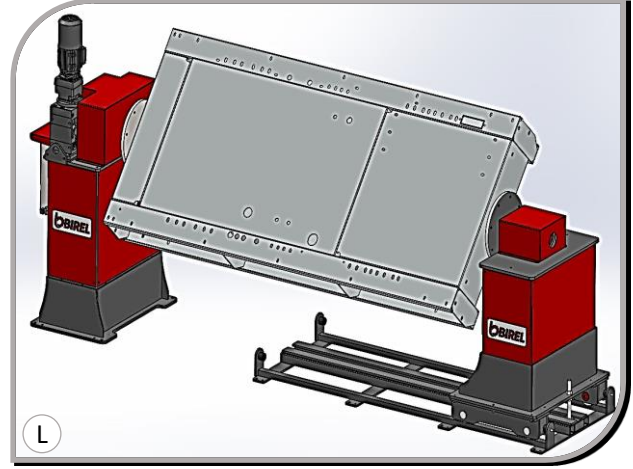

Standard Features

- Capability of 360 degree worktable rotation.
- Round Worktable with Holes (Adaptable to EFFA .Apparatus)
- Adjustable worktable rotation speed
- Rotational Speed Dijital display on Electrical Cabinet
- 5 m. Command Cable
- 5 m.Power Cable
- Brake & Fan Cooled Motor (Asynchronous)
- Standard Machine Colors:
 - Chassis RAL 7011(Grey)
 - Sheet Covers:RAL 3020(Red)
- Power Supply: 380V - (3 phase+Neutral +Earthing)
- One (1) Year Warranty (wearing parts out of warranty)

Optional Control Units

DFPSE

 Double Foot Pedal+Stick+
 Emergency Stop (3 m)

EFFA

Easy Fixture Fixing Apparatus



OHC

Overhead Hangable Control



WRC

Wireless Remote Control



❖ All technical specifications are subject to change without prior notice.

TECHNICAL PROPERTIES

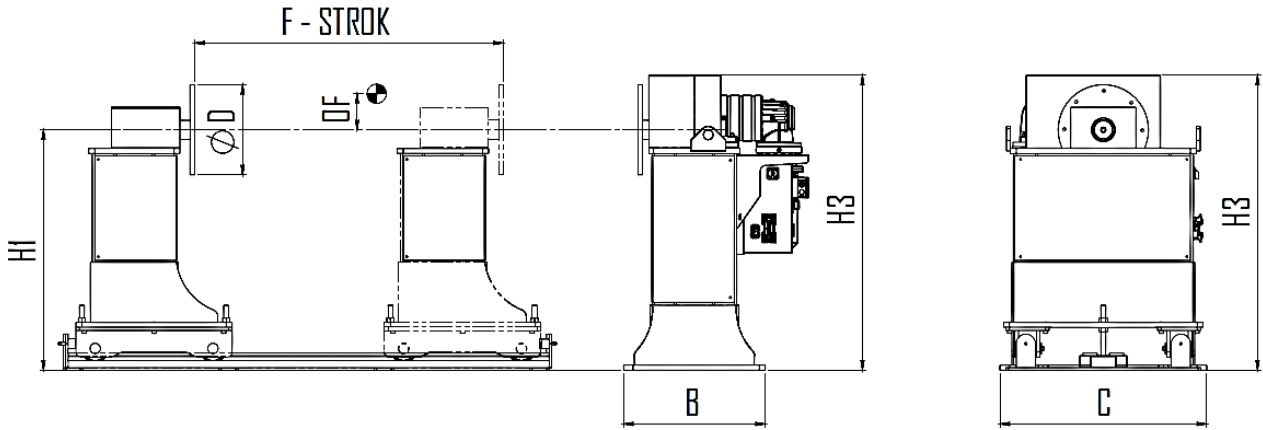

Technical Details :

Model : BEMG-1AX	Symb.	Unit	BEM1G-1AX	BEM2G-1AX	BEM3G-1AX	BEM5G-1AX
Capacity		kg	1 000	2 000	3 000	5 000
Rotation Speed		rpm	0,2-1,2	0,2-1,5	0,2-1	0,2-1,2
Max.Rotational Torque		Nm	1500	3000	4500	5000
Rotation Axle Height	H1	mm	1000	1000	1000	1250
Offset Distance	OF	mm	150	150	150	100
WorkTable Diameter	ØD	mm	375	375	375	500
Max.Workpiece Diameter		mm	2000	2000	2000	2500
Height	H3	mm	1220	1220	1250	1500
Length	B	mm	520	590	650	670
Width	C	mm	800	860	980	1060
Rail Type			By Birel			
Rail Stroke (F-STROKE)	F1 - F2	mm	1340	1250	1150	1100
Motor Power of WorkTable		kW	0,37	0,55	0,75	1,1
Weight		kg	590	910	1060	1460

↳ Out of these standard capacities, Birel Machinery, according to customer requirements, has the manufacturing possibility at different capacities, sizes.

❖ All technical specifications are subject to change without prior notice.