

- With standard set, 2 pcs.of Roller Carrier

- Up-Down Movement by Threaded Shaft.
- Up-Down Movement over Sliding guides.
- Adjustments by linear Measuring Scales,.
- Applying Hydraulic Pressing for holding pipe.

### OPTIONAL Modifications & Equipments

**M01:** Additional Each Carrier more than 2 pcs. is optional.

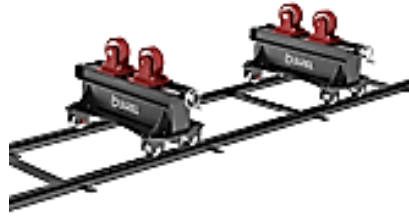

#### General Features ;

- BD Elbow Welding Rotator Model is used for the purpose of rotation and welding with round profiles in manual or automatic welding, mainly in the field of pipe construction, prefabrication and assembly on site.
- Due to rotation of pipe, No interruption is observed in circumferential welding of pipe.
- BD Elbow Welding Rotator Model, as standard, Up and down movement for diameter adjustment is performed mechanically by Manual Wheel. Upon request, Optionally, A quick mounting-detaching equipments can be provided.

#### Technical Advantages ;

- Birel Machinery as standard provides BD model in capacities of 6000 - 8000 kg.
- In special conditions, Out of these standard capacities, Birel Machinery, according to customer standards & requirements, has the opportunity of manufacturing possibility at different capacities.
- Motor with brake and forced fan cooling.
- Optionally, Welding Torch mounting equipment is provided
- For any special request or project, Please do not hesitate to contact with us.

❖ All technical specifications are subject to change without prior notice.

## ILLUSTRATIONS



A



B



C

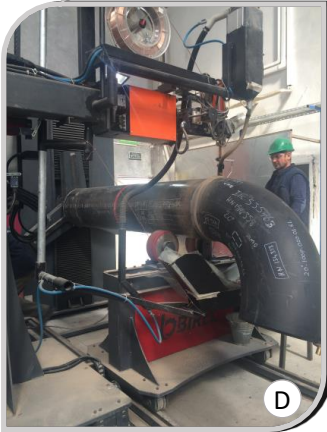

D



E

## Standard Equipments

- Capability of rotation.
- Up & Down movements for Diameter adjustment are provided by means of manually operated mechanical wheel as standard.
- Adjustable rotation speed & digital display on electrical cabinet
- 5 mt. Command Cable
- 5 mt. Power Cable
- Brake & Fan Cooled Motor (Asynchronous)
- Standard Machine Colors:
  - Chassis RAL 7011(Grey)
  - Sheet Covers:RAL 3020(Red )
- Power supply :380V - (3 phase)
- One (1) Year Warranty (wearing parts out of warranty)

## Optional Control Units

DFPSE

 Double Foot Pedal+Stick+  
 Emergency Stop (3 m)

OHC

Overhead Hangable Control



MP

Master Panel



WRC

Wireless Remote Controller



❖ All technical specifications are subject to change without prior notice.

## TECHNICAL PROPERTIES

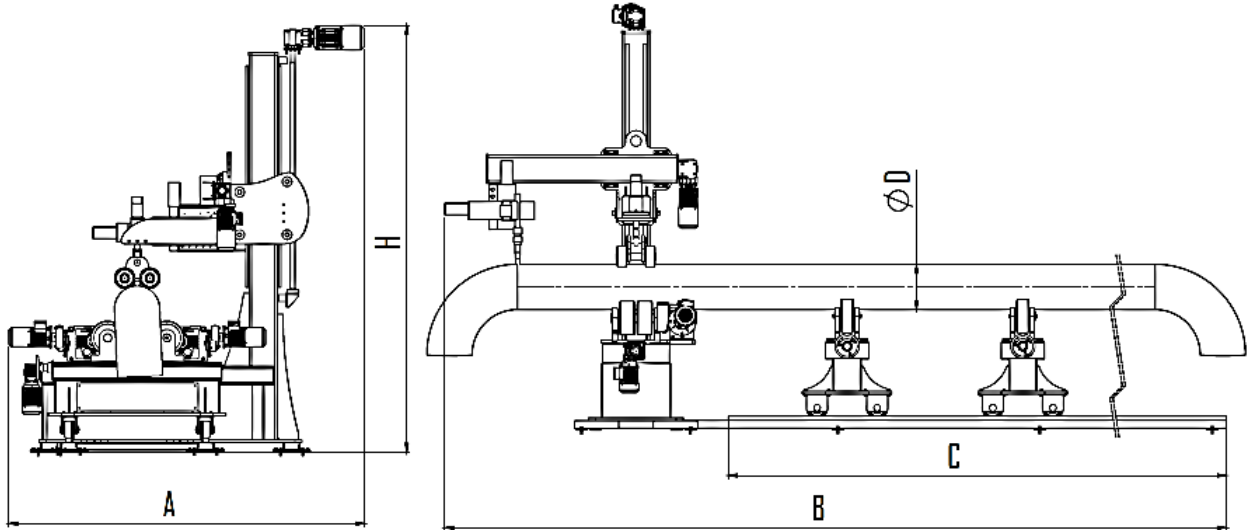

## Technical Details :

Model No : BD	Symb.	Unit	BD(4 - 24)	BD(12 - 56)
Capacity		kg	6 000	8 000
Mountable Pipe Diameter Range	Dmin - Dmax	inch	4" - 24"	12" - 56"
Machine Length	A	mm	2600	3150
Rail Axis	C	mm	11000	11000
Total Length	B	mm	13 000	13 000
Height	H	mm	3050	4800
Welding Speed		mm / min	200 - 1250	200 - 1250
Weight		kg	3700	5250

↪ Out of these std. capacities, Birel Machinery, according to customer requirements, has the manufacturing possibility at different capacities, sizes.

❖ All technical specifications are subject to change without prior notice.