

Mini  
BCP-020  
BCP-020-D

Chapter-A :WELDING POSITIONER MODELS | A01: Mini-Stationary Types  
Capacity-200kg. STANDARD Mini-Conventional Welding Positioner(2AX)

**BIREL**  
MÜHENDİSLİK MAKİNA A.Ş.

ABOUT PRODUCT STANDARD: with Slotted Table & HandBox Cable Remote Control

2  
Axis

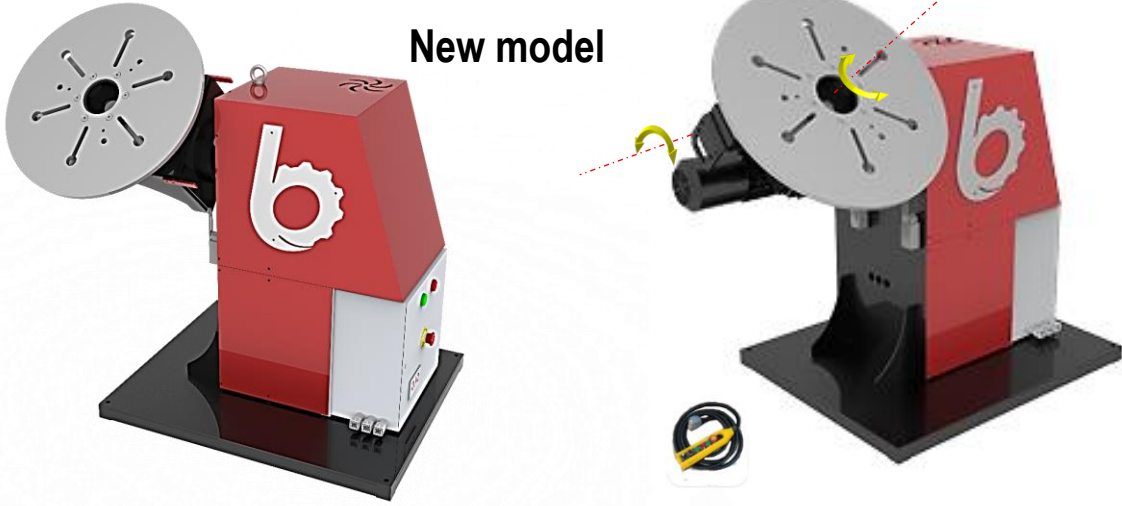

#### OPTIONAL Modifications & Equipments;

**T-SE** :Round Worktable T-Side Entry Grooved  
Thick Table Plate

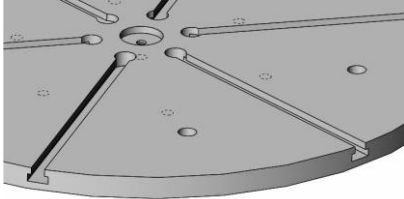

**MC** : Manual Chuck



#### General Features ;

- Mini-BCP model Conventional Positioner is designed at best suitable configuration to supply function of worktable rotation & tilting of worktable angularly.
- Mini-BCP model Conventional Positioner as structurally has the best protective system. Against heavy parts positioner should be anchored to the facility ground.
- Mini-BCP model Conventional positioner, without considering of any geometric shape, all parts within dimensions has capability of positioning & forming suitable welding edge.
- Mini-BCP model Conventional positioner, as structurally are constituted of Body, Motor, Worktable rotation and tilting systems, electric panel and cable remote operator control.
- The rotation & tilting movements of Mini-BCP model Conventional Positioner are done by means of gear transmission system.
- Enable quick connection of workpiece by means of Slot Groove or T-Grooved worktable.
- Mini-BCP Conventional positioner WorkTable is supplied as standard with T-Side Entry grooved. Optionally, If Worktable is requested as T-Grooved Thick Plate also can be manufactured as an option.

#### Technical Advantages ;

- Birel Machinery as standard provides Mini-BCP models in capacities of 50 - 100 - 200 kg..
- In special conditions, Out of these standard capacities, Birel Machinery, according to customer standards & requirements, has the opportunity of manufacturing possibility at different capacities.
- Motor with brake and forced fan cooling
- Welding Arc Group
- For any special request or project, Please do not hesitate to contact with us.

❖ All technical specifications are subject to change without prior notice.

Birel Mühendislik Makine San. Tic. A.Ş. | Adresses: Yaylacık Mahallesi Dogancilar Mevkii 46. Sok. No:4/1 Nilüfer/Bursa – TURKEY  
Tel: +90 (224) 413 0617 Fax: +90 (224) 413 0618 Web : [www.birelmuhendislik.com](http://www.birelmuhendislik.com) Contact Email : [info@birelmuhendislik.com](mailto:info@birelmuhendislik.com)  
Sales: Email: [sales@birelmakina.com](mailto:sales@birelmakina.com) Direct Mobil: +90.5462016491

Mini  
BCP-020  
BCP-020-D

Chapter-A :WELDING POSITIONER MODELS | A01: Mini-Stationary Types  
Capacity-200kg. STANDARD Mini-Conventional Welding Positioner(2AX)

**BIREL**  
MÜHENDİSLİK MAKİNA A.Ş.

## FEATURES

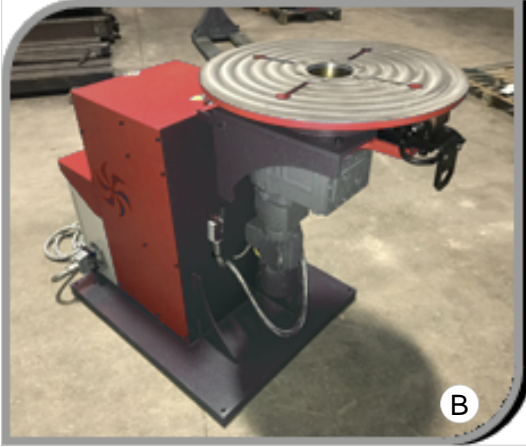

### Standard Features

- Round Worktable with Slots.
- Adjustable worktable rotation speed
- Rotational Speed Dijital display on Electrical Cabinet
- Mechanical gear movement for tilting.
- Limit Switches to terminate movement.
- 3 m. Command Cable with Hand Control Unit.
- 3 m.Power Cable
- Brake & Fan Cooled Motor (Asynchronous)
- Welding Arc Group
- Standard Machine Colors:
  - Chassis RAL 7011(Grey)
  - Sheet Covers:RAL 3020(Red )
- Power Supply: 380V - (3 phase+Neutral +Earthing)
- One (1) Year Warranty (wearing parts out of warranty)

### Optional Control Units

DFPSE

Double Foot Pedal+Stick+  
Emergency Stop (3 m )



OHC

Overhead Hangable Control



SFP

Single Foot Pedal



WRC

Wireless Remote Control



❖ All technical specifications are subject to change without prior notice.

Birel Mühendislik Makine San. Tic. A.Ş. | Adresses: Yaylacik Mahallesi Dogancilar Mevkii 46. Sok. No:4/1 Nilüfer/Bursa – TURKEY  
Tel: +90 (224) 413 0617 Fax: +90 (224) 413 0618 Web : [www.birelmuhendislik.com](http://www.birelmuhendislik.com) Contact Email : [info@birelmuhendislik.com](mailto:info@birelmuhendislik.com)  
Sales: Email: [sales@birelmakina.com](mailto:sales@birelmakina.com) Direct Mobil: +90.5462016491

TECHNICAL PROPERTIES

Mini-BCP-020 and Mini-BCP-020-D

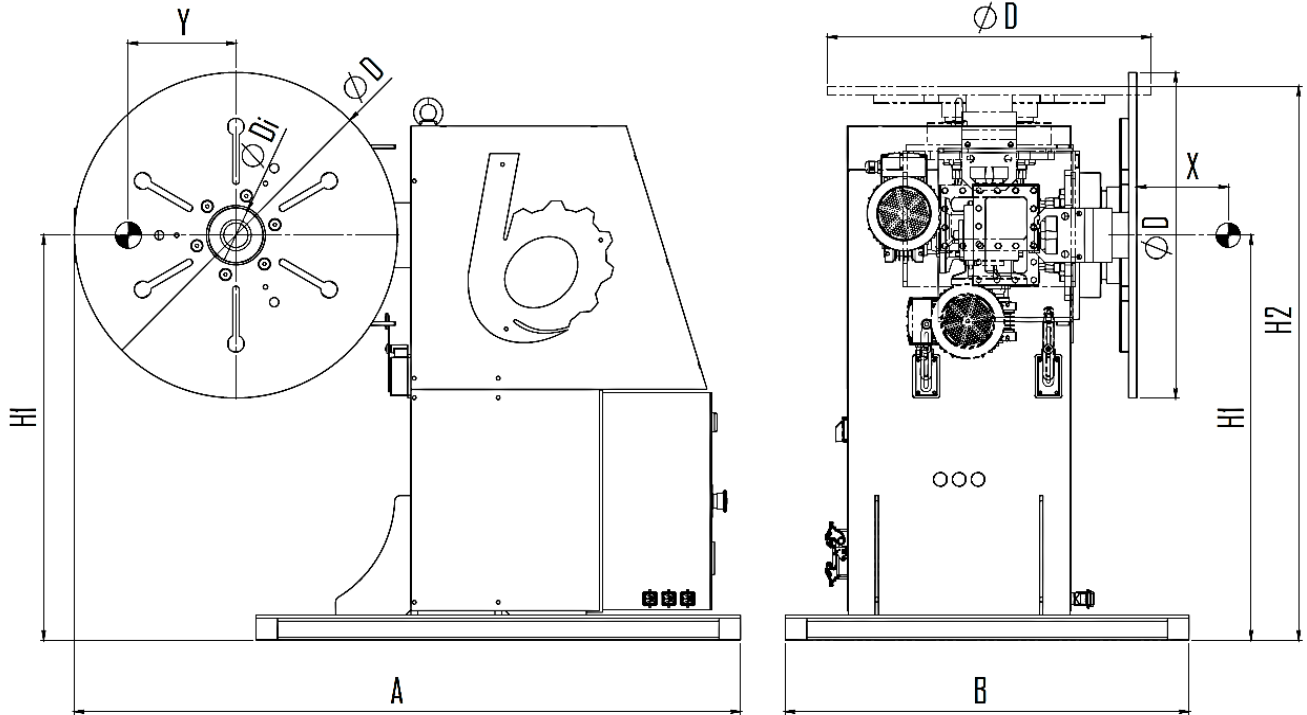

Technical Details :

Mini-BCP model	Symb	Unit	Mini-BCP020	Mini-BCP020-D
Capacity		kg	200	200
Rotation Speed		rpm	0,22-2,2	0,38-3,8
Max.Rotational Torque		Nm	300	300
Tilting Angle		deg	90-0-90	90-0-90
Tilting Torque		Nm	685	685
Max.Welding Current		Amp	400	400
Offset Distance	X-Y	mm	150 - 150	150-150
Table Plate Diameter	ØD	mm	600	500
Hollow Shaft	ØDi	mm	100	100
Hollow Shaft Up to Depth		mm	60	Through all
Height (Table Vertical)	H1	mm	750	750
Height (Table Parallel)	H2	mm	1020	1020
Length	A	mm	1240	1240
Width	B	mm	750	750
Motor Power of Table		kW	0,25	0,25
Motor Power of Tilting		kW	0,25	0,25
Weight		kg	350	325

↪ Out of these standard capacities, Birel Machinery, according to customer requirements, has the manufacturing possibility at different capacities, sizes.

❖ All technical specifications are subject to change without prior notice.