

Mini

BCP-010-SA

Chapter-A : WELDING POSITIONER MODELS | A01: Mini-Stationary Types

STANDARD Mini-Conventional SEMI-AUTOMATIC Welding Positioner

BIREL
MÜHENDİSLİK MAKİNA A.Ş.

ABOUT PRODUCT



- ❖ Pneumatic Pressing,
- ❖ Overlapping of welding at the end of cycle by time delay.
- ❖ Adjustment of Tilting Angle by means of Manuel HandWheel (0-90°)
- ❖ Manual adjustment of Torch holder Angle and Height.
- ❖ Ergonomic Table.



Standard Features

- Round Worktable with Slots.
- Adjustable worktable rotation speed by Potentiometer
- Manual Mechanical gear movement for tilting by Handwheel. With opportunity of adjusting at every angle within range.
- 3 m. Power Cable
- Standard Machine Colors:
 - Chassis RAL 7011(Grey)
 - Sheet Covers:RAL 3020(Red)
- Power Supply : 220V - (2 phase) (DC Current)
- One (1) Year Warranty (wearing parts out of warranty)

❖ All technical specifications are subject to change without prior notice.

Birel Mühendislik Makine San. Tic. A.Ş. | Adresses: Yaylacik Mahallesi Dogancilar Mevkii 46. Sok. No:4/1 Nilüfer/Bursa – TURKEY
Tel: +90 (224) 413 0617 Fax: +90 (224) 413 0618 Web : www.birelmuhendislik.com Contact Email : info@birelmuhendislik.com
Sales: Email: sales@birelmakina.com Direct Mobil: +90.5462016491

Mini

BCP-010-SA

Chapter-A :WELDING POSITIONER MODELS | A01: Mini-Stationary Types
STANDARD Mini-Conventional SEMI-AUTOMATIC Welding Positioners

BIREL
MÜHENDİSLİK MAKİNA A.Ş.

FEATURES

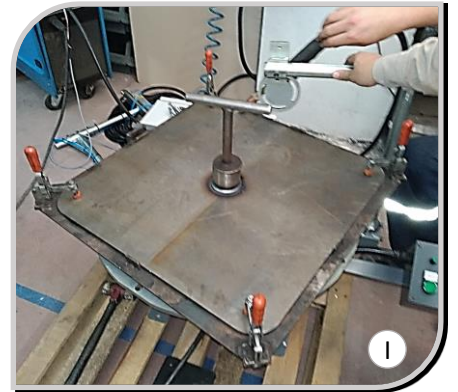
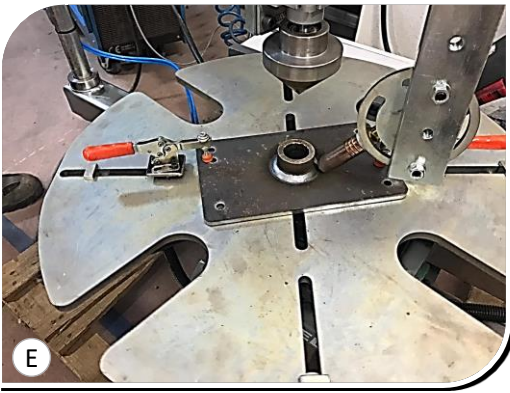
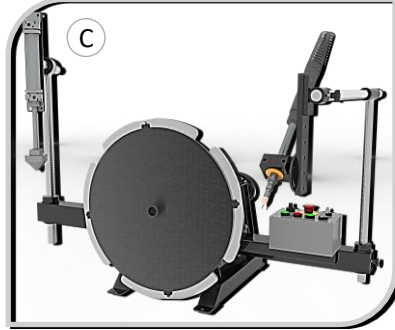
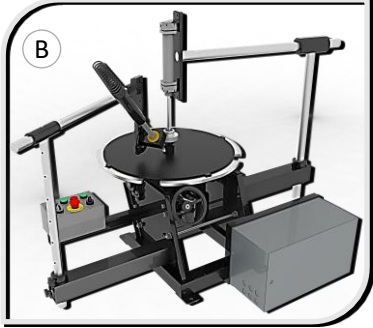

❖ All technical specifications are subject to change without prior notice.

Birel Mühendislik Makine San. Tic. A.Ş. | Adresses: Yaylacik Mahallesi Dogancilar Mevkii 46. Sok. No:4/1 Nilüfer/Bursa - TURKEY
Tel: +90 (224) 413 0617 Fax: +90 (224) 413 0618 Web : www.birelmuhendislik.com Contact Email : info@birelmuhendislik.com
Sales: Email: sales@birelmakina.com Direct Mobil: +90.5462016491

Mini

BCP-010-SA

Section-A :WELDING POSITIONER MODELS | A01: Mini-Stationary Types
Capacity-100kg. STAND. Mini-Conventional SEMI-AUTOMATIC Welding Pos.

BIREL
MÜHENDİSLİK MAKİNA A.Ş.

TECHNICAL FEATURES

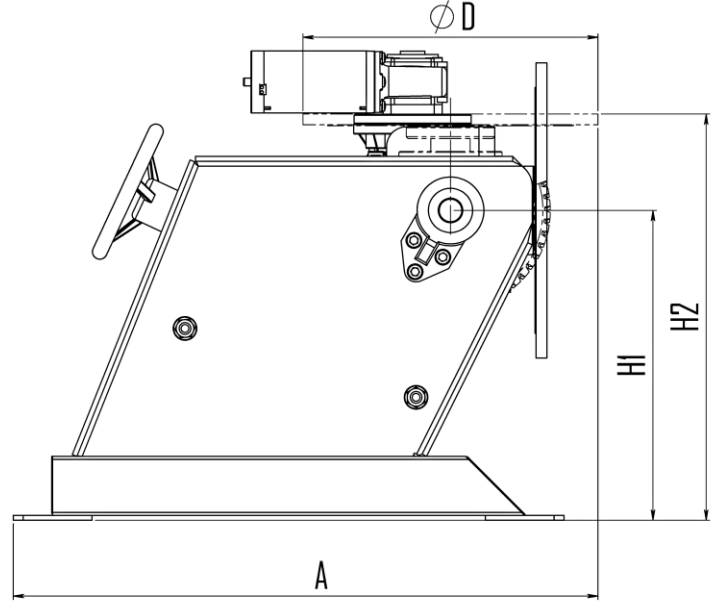
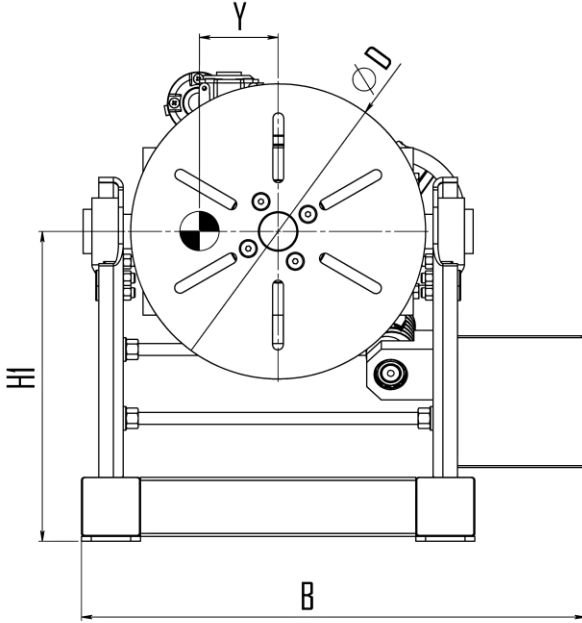

Technical Details :

Mini-BCP-SA model	Symb.	Unit	Mini-BCP010-SA
Capacity		kg	100
Rotation Speed		rpm	0 - 2,3
Max.Rotational Torque		Nm	86
Tilting Angle		deg	0 - 90°
Tilting Torque		Nm	Manual
Offset	X- Y	mm	Y=50
Work Plate Diameter	ØD	mm	300
Height (Table Vertical)	H1	mm	315
Height (Table Parallel)	H2	mm	415
Length	A	mm	595
Width	B	mm	513
Motor Power of Table		kW	0,1 (DC)
Motor Power of Tilting			Manual
Weight		kg	57

↳ Out of these standard capacities, Birel Machinery, according to customer requirements, has the manufacturing possibility at different capacities, sizes.

❖ All technical specifications are subject to change without prior notice.

Birel Mühendislik Makine San. Tic. A.Ş. | Adresses: Yaylacik Mahallesi Dogancilar Mevkii 46. Sok. No:4/1 Nilüfer/Bursa - TURKEY
Tel: +90 (224) 413 0617 Fax: +90 (224) 413 0618 Web : www.birelmuhendislik.com Contact Email : info@birelmuhendislik.com
Sales: Email: sales@birelmakina.com Direct Mobil: +90.5462016491